

KINNEY AUTOMATIC SELF-CLEANING STRAINER



APPLICATION

Designed for continuous removal of suspended particles from all types of liquids. Applications are in industrial plants using river, lake, well, or sea water for cooling, descaling, bearing lubrication, spraying, quenching, and similar purposes. Pipe-line sizes: 6"-48" or larger upon application.

Liquids other than water, such as chemicals, acids, white water (paper mills), sewage, and ammonia flushing liquor (coke plants) can also be effectively strained.

INSTALLATION

Installation is made on the discharge side of a pump or in any piping system operating under a positive pressure. The minimum working pressure required to effectively clean the straining media is 20 psi. The strainer is compact with small face-to-face, width, and height dimensions.

DESIGN

The strainer consists of a cylindrical drum with a number of threaded holes containing one of many types of straining media. The drum is supported on a rotating shaft fitted with bearings and is contained in a body having a vertical backwash slot opening adjacent to the drum surface.

OPERATION

The liquid to be strained enters the inlet connection located in the lower portion of the body and flows around the outer surface of the drum. The suspended particles are retained in the media pockets and the clean liquid passes through the media to the inside and bottom opening of the drum—leaving the body at the outlet connection located diametrically opposite the inlet.

BACKWASH

As each row of straining media passes the backwash slot, a reversal of flow occurs, flushing the suspended particles from the media pockets. This reversal of flow is caused by a pressure differential between the interior of the strainer and atmosphere. The backwash flow rate is exceptionally low and will vary, depending on the amount of suspended particles in the liquid. The backwash piping should discharge into an open funnel immediately after the backwash valve.

AUTOMATIC BACKWASH CONTROL

In lieu of a manually operated valve on the backwash outlet line, an automatic control can be furnished to permit intermittent backflushing. This control consists of a motor or pneumatic cylinder operated ball valve, actuated by a timer or a pressure differential switch (or both).

ADJUSTMENT AND SHEARING ACTION

The clearance between the backwash slot and the drum is equal to or smaller than the opening presented in the media—and can be adjusted easily by two locknuts on the threaded part of the top section of the shaft. The backwash slot contains a knife-like edge which enables the strainer to shear debris such as wood, shells, fish, and other suspended materials which may extend beyond the surface of the drum—with no resultant damage to the drum, straining media, or drive unit.

INSPECTION

The Kinney strainer eliminates troublesome disassembly by providing an opening in the side of the strainer body. To inspect the straining media, simply remove the cover and manually rotate the drum (via a special shaft in the drive unit). As each row of media passes the inspection opening, easy access to the media is achieved.

MODEL A
Fabricated

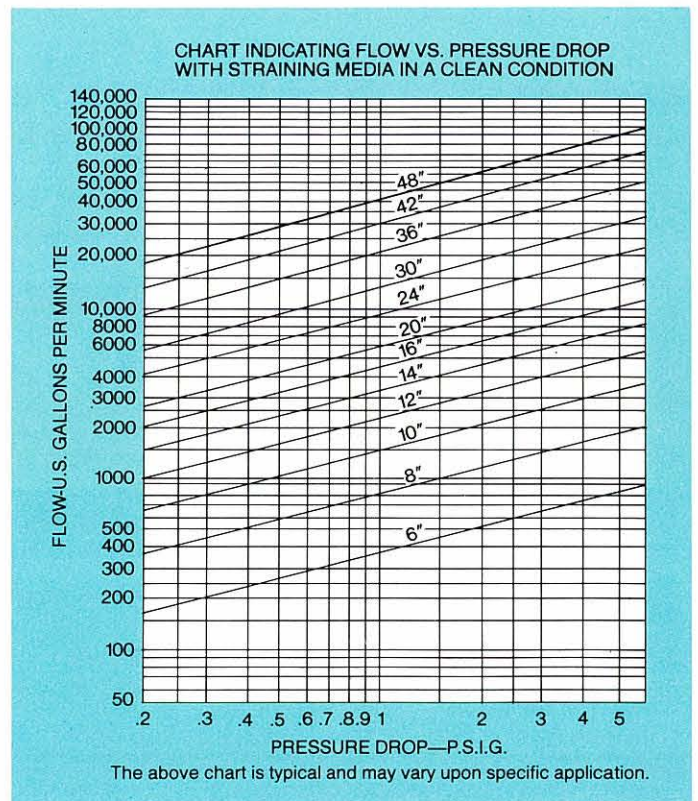
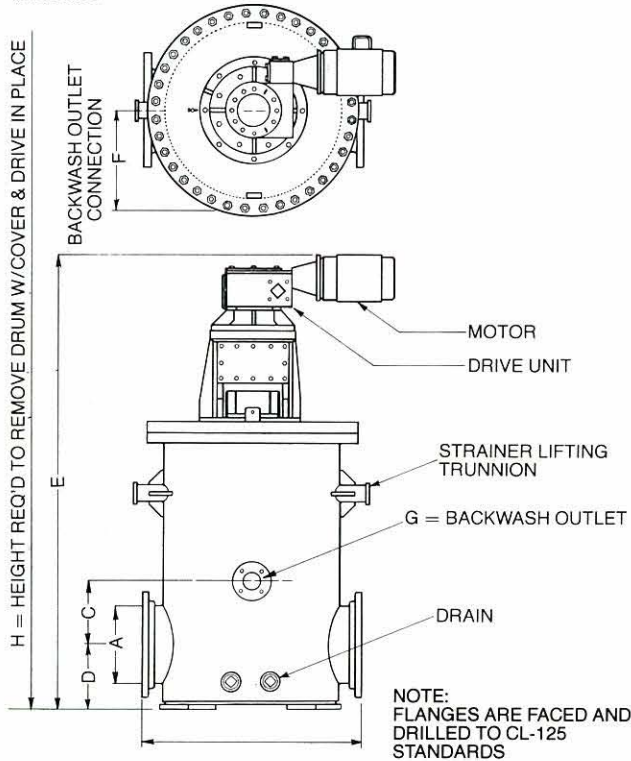

MODEL A FABRICATED								
STRAINER SIZE-A	DIMENSIONS (INCHES)							APPROX. SHIP. WT. LBS.
	B	C	D	E	F	G	H	
6	21	7	7	49½	10½	2▲	64	1,150
8	26	8	8¼	59¼	12½	2▲	77¾	1,497
10	31	9¾	9½	62⅞	16¼	3▲	83¼	2,350
12	36	11½	11	78¼	19	3▲	105¾	3,452
14	41	12½	12	81½	19	4	109	4,197
16	45	13¼	13¼	92⅞ ₁₆	20¾	3*	127¼	6,000
20	52	15½	15¼	101⅞ ₁₆	24¼	4*	141¼	8,223
24	62	17½	17½	116¾	28½	4*	167½	11,904
30	72	23½	21½	130½	32¾	6*	184½	15,892
36	86	25½	25	153¾	40	6*	211	25,352
42	93	30½	31½	196¾	42¾	6*	267½	32,500
48	120	45	55½	227	52¾	8*	391½	58,000

*Two backwash openings ▲ Pipe tap Do not use for construction—certified prints will be furnished

PART	CONSTRUCTION			
	STANDARD	SEA WATER	WHITE WATER	AMMONIACAL LIQUOR
BODY	Fabricated Steel (Epoxy Lined)	Fabricated Steel (Epoxy Lined) or Stainless Steel	Stainless Steel	Fabricated Steel
DRUM	Cast Iron	Ni-Resist	Stainless Steel	Cast Iron
MEDIA	As Specified	As Specified	As Specified	As Specified
MEDIA RETAINERS	Delrin	Stainless Steel	Delrin	Stainless Steel
SHAFT	Steel	Stainless Steel	Stainless Steel	Stainless Steel



S. P. KINNEY ENGINEERS, INC.
143 FIRST AVE. • CARNEGIE, PENNSYLVANIA 15106
PHONE: AREA CODE (412) 276-4600