



BOS OFFSET DISC RESILIENT- SEATED BUTTERFLY VALVES TECHNICAL SPECIFICATIONS



Materials of Construction

2-20" Valves (50-500mm)

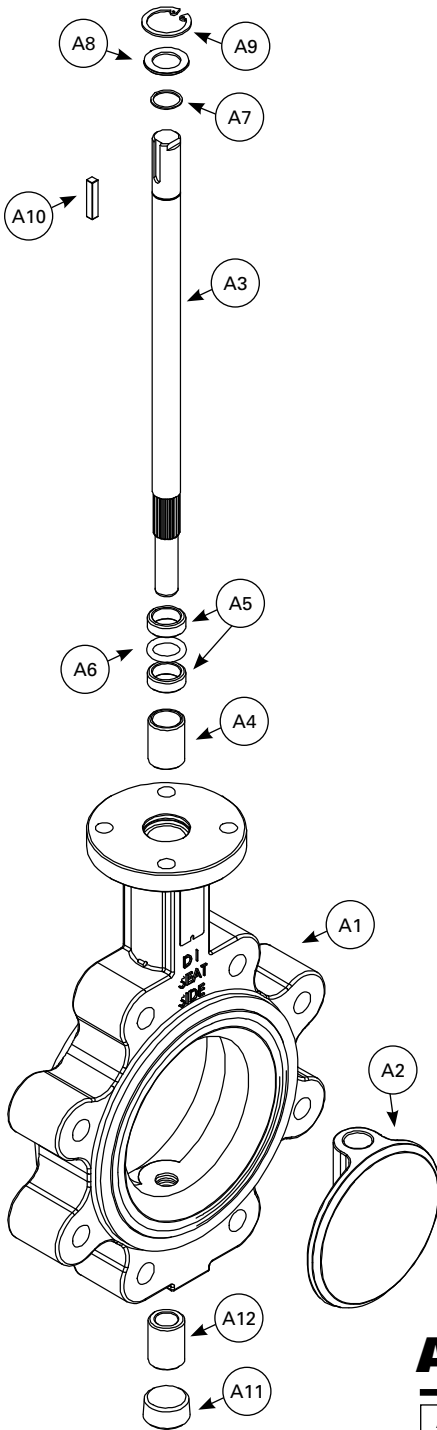

Wafer and Lugged Design

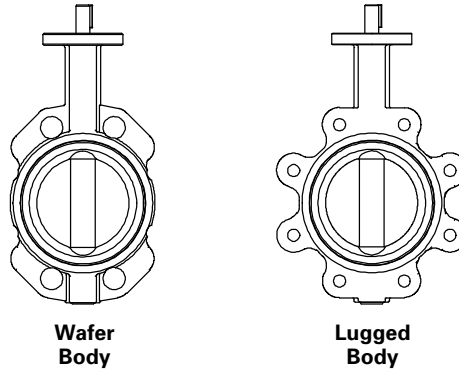

2-20" Valves (50-500mm)

Item	Description	Material
A1	Body/Seat Molding	Ductile Iron, ASTM A536, 65-45-12/NBR – Acrylonitrile-Butadiene
		Ductile Iron, ASTM A536, 65-45-12/EPDM – Terpolymer of Ethylene Propylene and a Diene
		Ductile Iron, ASTM A536, 65-45-12/FKM – Fluoro-Elastomer
A2	Disc	Ductile Iron, ASTM A536, 65-45-12, Nickel Plated
		Aluminum Bronze, ASTM B148, C954
		316 Stainless Steel, ASTM A743, CF8M
A3	Shaft	316 Stainless Steel, ASTM A276
		416 Stainless Steel, ASTM A582
A4	Middle Bearing	Aluminum Bronze, ASTM B148, C954
A5	Upper Bearing (2)	Aluminum Bronze, ASTM B148, C954
A6	O-ring	NBR – Acrylonitrile-Butadiene
		EPDM – Terpolymer of Ethylene Propylene and a Diene
		FKM – Fluoro-Elastomer
A7	Retainer Ring	302 Stainless Steel, ASTM A276
A8	Washer	416 Stainless Steel, ASTM A582
A9	Retaining Ring	Steel ASTM A29M
A10	Key	AISI 1020 Steel
A11	Pipe Plug	Cast Iron Zinc Plated
A12	Lower Bearing	Aluminum Bronze, ASTM B148, C954

Applicable Standards

ANSI B16.1	Conforms to ANSI Class 125 flange drilling.
ANSI B16.5	Conforms to ANSI Class 150 flange drilling.
ANSI B16.42	Conforms to ANSI Class 150 flange drilling, body wall thickness and pressure-temperature ratings.
ANSI B16.104	Exceeds Class VI shutoff requirements.
API 609	Butterfly Valves Category A.
AWWA C504	Diameter of stainless steel shaft meets AWWA Class 75B standard. Body wall thickness exceeds the AWWA Class 150B standard for butterfly valve.
MSS SP-25	Markings and identification conform to the requirements.
MSS SP-67	Butterfly Valves
ISO 5211	Actuator Mounting
International Flange Drilling	Metric flange drilling (W110 and L110) = ISO 7005-2, DIN or BS4504 PN10 Drilling Metric flange drilling (W116 and L116) = ISO 7005-2, DIN or BS4504 PN16 Drilling

Valve Selection

Pressure Ratings

Zero-leakage bi-directional shutoff to 250 psi Cold Working Pressure with 416 stainless steel shaft and 200 psi Cold Working Pressure with 316 stainless steel shaft.

Pipeline Velocity Range

BOS resilient-seated butterfly valves can be used at pipeline velocities up to 20 feet per second (6 meters per second). For applications greater than 20 feet per second, contact DeZURIK

Valve Weights

Valve Size	Wafer		Lugged	
	Lbs.	Kg	Lbs.	Kg
2" 50mm	6	3	8	4
2.5" 65mm	8	4	9	4
3" 80mm	10	5	12	6
4" 100mm	16	7	20	9
5" 125mm	20	9	25	11
6" 150mm	28	13	32	15
8" 200mm	43	20	49	22
10" 250mm	62	28	76	35
12" 300mm	102	46	124	56
14" 350mm	143	65	161	73
16" 400mm	218	99	264	120
18" 450mm	292	132	331	150
20" 500mm	369	167	505	229

Actuator Weights

Cylinder Actuator

Actuator Size	Weight lbs/kg
GS-2A-PC6	$\frac{36}{16}$
GS-4A-PC8	$\frac{78}{35}$
GS-6A-PC8	$\frac{92}{42}$
GS-12A-PC6	$\frac{180}{82}$
GS-12A-PC8	$\frac{204}{93}$
GS-12A-PC10	$\frac{234}{106}$

Manual Gear Actuator

Basic

Actuator Size	Weight lbs/kg
MG-7	$\frac{8}{4}$
MG-1012	$\frac{10}{5}$
MG-1216	$\frac{25}{11}$
MG-16	$\frac{36}{16}$
GS-12A	$\frac{113}{51}$

Handwheel

Handwheel Size	Weight lbs/kg
HD-8	$\frac{8}{4}$
HD-12	$\frac{11}{5}$
HD-16	$\frac{18}{8}$
HD-20	$\frac{22}{10}$
HD-24	$\frac{26}{12}$

Chainwheel

Chainwheel Size	Weight lbs/kg
CW-8	$\frac{11}{5}$
CW-12	$\frac{16}{7}$
CW-20	$\frac{42}{19}$
CW-24	$\frac{62}{28}$

Lever Actuator

Lever Length	Weight lbs/kg
LT (10.5")	$\frac{1.85}{.84}$

Ordering

To order, simply complete the valve order code from information shown.

Valve Style

Give valve style code as follows:

BOS = Offset Disc Resilient-Seated Butterfly Valve

Valve Size

Give valve size code as follows:

2 = 2" (50mm)	10 = 10" (250mm)
2.5 = 2.5" (65mm)	12 = 12" (300mm)
3 = 3" (80mm)	14 = 14" (350mm)
4 = 4" (100mm)	16 = 16" (400mm)
5 = 5" (125mm)	18 = 18" (450mm)
6 = 6" (150mm)	20 = 20" (500mm)
8 = 8" (200mm)	

Body Style

Give body style code as follows:

US = Uninterrupted Seat (2" - 20")

End Connection

Give end connection code as follows:

Wafer

W1 = ANSI Class 125/150 Wafer Drilling

On Application

W110 = ISO 7005-2, DIN or BS4504 PN10 Drilling

W116 = ISO 7005-2, DIN or BS4504 PN16 Drilling

Lugged

L1 = ANSI Class 125/150 Lugged Drilling

On Application

L110 = ISO 7005-2, DIN or BS4504 PN10 Drilling

L116 = ISO 7005-2, DIN or BS4504 PN16 Drilling

Body Material

Give body material code as follows:

DI = Ductile Iron

Seat, Shaft Seal Material Combination

Give seat, shaft material code as follows:

NBR,NBR = Acrylonitrile-Butadiene
+10° to +180°F (-12 to 82°C)
EPDM,EPDM = Terpolymer of Ethylene Propylene & a Diene
-30° to +250°F (-35 to +121°C)

Optional Seat Material

FKM,FKM = Fluoro Elastomer
+10° to +400°F (-12 to +204°C)

Trim Combination

Disc Material - Shaft Material

Give disc-shaft material code as follows:

Standard Disc Material-Shaft Material

250 PSI Service:

ALB-S4 = Aluminum Bronze Disc -
416 Stainless Steel Shaft

DI-S4 = Ductile Iron Nickel Plated Disc -
416 Stainless Steel Shaft

200 PSI Service:

S2-S2 = 316 Stainless Steel Disc -
316 Stainless Steel Shaft

(MG) Manual Worm Gear Actuator Sizing

Valve Size	Handwheel Order Code	Chainwheel Order Code	Max. Shutoff Pressure Differential psi/kPa
2-6" 50mm-150mm	MG-7-HD8	MG-7-CW8	250 1720
8" & 10" 200mm-250mm	MG-1012-HD8	MG-1012-CW8	250 1720
12" 300mm	MG-1012-HD12	MG-1012-CW12	250 1720
14" 350mm	MG-1012-HD16	MG-1012-CW20	100 690
	MG-1216-HD16	MG-1216-CW20	250 1720
16" 400mm	MG-1216-HD20	MG-1216-CW20	250 1720
18" 450mm	MG-16-HD24	MG-16-CW24	200 1380
	GS-12A-HD20	GS-12A-CW20	250 1720
20" 500mm	MG-16-HD24	MG-16-CW24	100 690
	GS-12A-HD20	GS-12A-CW20	250 1720

(LT) Ten Position Lever Sizing

Valve Size	Actuator Order Code	Max. Shutoff Pressure Differential psi/kPa
2-6" 50mm-150mm	LT	250 1720

Ordering Example:

BOS,6,W1,DI,NBR,NBR,DI-S4*actuator

(GS) Cylinder Actuator Sizing
50 PSI (340 kPa) & 80 PSI (550 kPa) Air Supply

Valve Size	Actuator Order Code	Max. Shutoff Pressure Differential psi/kPa		
		50 PSI (340 kPa)	50 PSI (340 kPa)	80 PSI (550 kPa)
2-5" 50mm-125mm	GS-2A-PC6	250 1720	250 1720	250 1720
6" 150mm	GS-2A-PC6	50 340	250 1720	250 1720
	O/A	250 1720	—	—
8" 200mm	GS-4A-PC8	250 1720	250 1720	250 1720
10" 250mm	GS-4A-PC8	200 1380	250 1720	250 1720
	O/A	250 1720	—	—
12" 300mm	GS-4A-PC8	50 340	150 1030	250 1720
	GS-6A-PC8	250 1720	250 1720	—
14" 350mm	GS-4A-PC8	—	75 515	125 860
	GS-6A-PC8	50 340	100 690	250 1720
	GS-12A-PC8	250 1720	250 1720	—
16" 400mm	GS-12A-PC6	50 340	100 690	250 1720
	GS-12A-PC8	250 1720	250 1720	—
18" 450mm	GS-12A-PC8	100 690	200 1380	250 1720
	GS-12A-PC10	250 1720	250 1720	—
20" 500mm	GS-12A-PC8	100 690	150 1030	250 1720
	GS-12A-PC10	250 1720	250 1720	—

Actuators

Cylinder Actuators

Double-acting cylinder actuators feature a proven rack-and-pinion design and provide high torque output throughout the full stroke for accurate control.



Manual Gear Actuators

Manual gear actuators feature ductile iron gear sectors and heavy duty thrust bearings on the input shaft for durability and performance.

Lever Actuators

A 10-position dial provides positive latching in open, closed and eight intermediate positions.

Seat Side

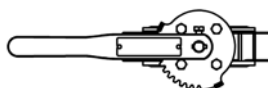

Standard Position

Seat Side

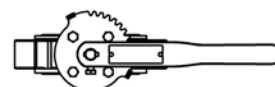

180° Position



Ordering

To order, add lever code to basic valve identification. Handwheel actuators are recommended for valves 6" (150mm) and larger where water hammer may occur due to a sudden valve closure.

Ordering Example:

BOS,6,W1,DI,NBR,NBR,DI-S4*LT

Dimensions

DISC POSITION INDICATED BY LINE ON TOP OF SHAFT

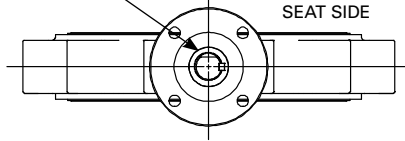

DISC POSITION INDICATED BY LINE ON TOP OF SHAFT

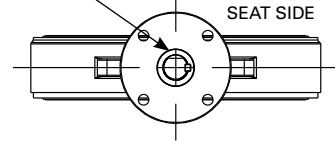

MOUNTING HOLES FOR PIPELINE MOUNTING "F" QTY AND SIZE OF TAPPED THROUGH HOLES "G" DIA BC (ANSI STANDARDS)

"B" DIA

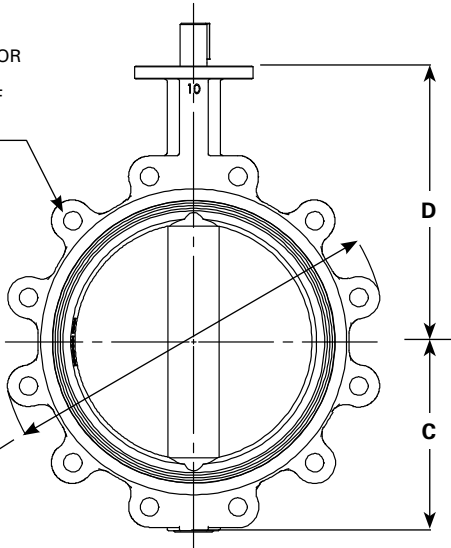

Lugged

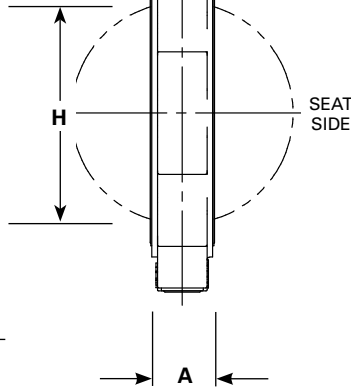

4 LOCATING HOLES FOR PIPELINE MOUNTING "F" DIA OF THROUGH HOLES "G" DIA BC (ANSI STANDARDS)

"B" DIA

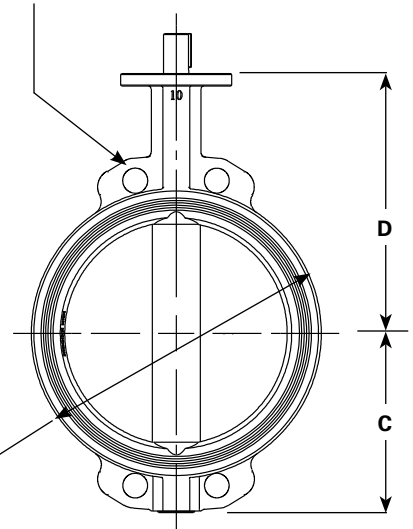

Wafer

Basic Valve

Valve Size	A	B		C	D	F		G	H Disc Clearance
		Lugged	Wafer			Lugged	Wafer		
2" 50mm	1.69 43	6.42 163	3.90 99	3.31 84	5.79 147	4 5/8-11 UNC	.75 19	4.75 121	1.70 43
2.5" 65mm	1.81 46	7.00 178	4.41 112	3.31 84	6.10 155	4 5/8-11 UNC	.75 19	5.50 140	2.09 53
3" 80mm	1.81 46	7.50 191	5.10 130	3.54 90	6.50 165	4 5/8-11 UNC	.75 19	6.00 152	2.62 67
4" 100mm	2.06 52	9.00 229	6.42 163	4.47 114	7.52 191	8 3/4-10 UNC	.88 22	7.50 191	3.61 92
5" 125mm	2.19 56	10.00 254	7.58 193	4.82 122	8.11 206	8 3/4-10 UNC	.88 22	8.50 216	4.58 116
6" 150mm	2.19 56	11.00 279	8.74 222	5.51 140	8.62 219	8 3/4-10 UNC	.88 22	9.50 241	5.55 141
8" 200mm	2.38 60	13.33 339	10.86 276	6.75 171	10.24 260	8 3/4-10 UNC	.88 22	11.75 298	7.55 192
10" 250mm	2.69 68	16.00 406	12.84 326	7.93 201	11.50 292	12 7/8-9 UNC	1.00 25	14.25 362	9.57 243
12" 300mm	3.06 78	18.89 480	15.25 387	9.06 230	13.35 339	12 7/8-9 UNC	1.00 25	17.00 432	11.68 297
14" 350mm	3.06 78	21.72 552	17.32 440	10.14 258	14.50 368	12 1-8 UNC	1.12 28	18.75 476	12.70 323
16" 400mm	4.00 102	23.48 596	18.97 482	11.81 300	15.83 402	16 1-8 UNC	1.12 28	21.25 540	14.80 376
18" 450mm	4.50 114	26.12 663	21.30 541	12.93 328	16.62 422	16 1-1/8-8 UNC	1.25 32	22.75 578	16.49 419
20" 500mm	5.00 127	28.59 726	23.38 594	14.06 357	18.90 480	20 1-1/8-8 UNC	1.25 32	25.00 635	18.24 463

Inch
Millimeter

Basic Valve

Lever & Valve 2-6" (50-150mm)

Valve Size	Dimensions		
	A	B	C
2-6" 50-150mm	10.53 267	2.37 60	1.25 32

Inch
Millimeter

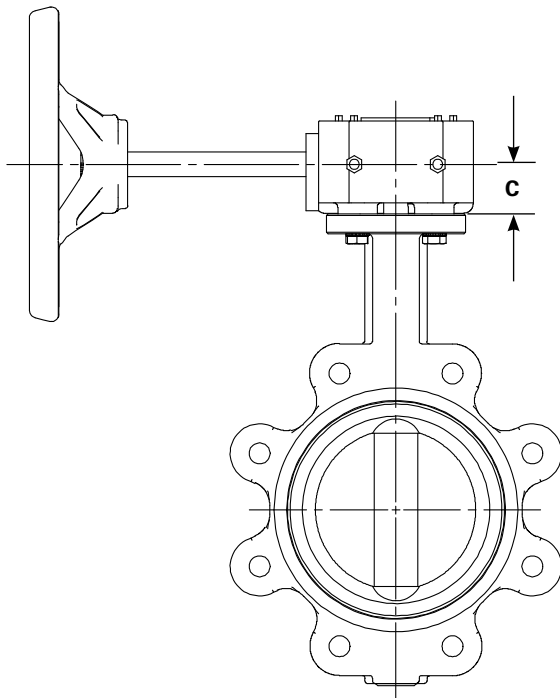
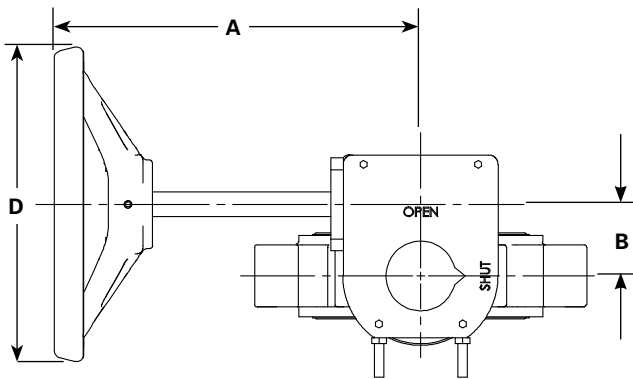
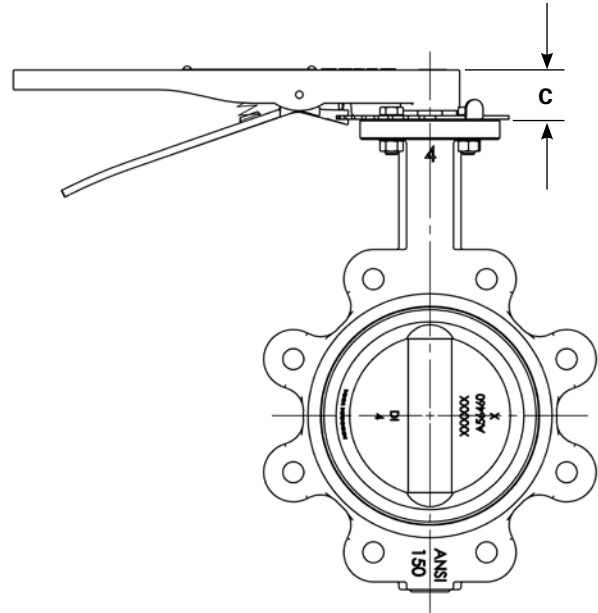
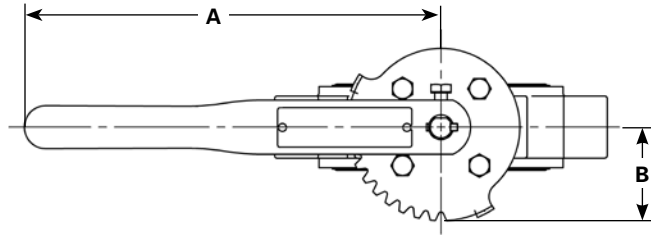

Manual Handwheel & Valve 2-20" (50-500mm)

Valve Size	Handwheel Code	Dimensions			
		A	B	C	D
2-6" 50-150mm	MG-7-HD8	9.31 236	1.82 46	1.26 32	8.00 203
8-10" 200-250mm	MG-1012-HD8	12.57 319	2.36 60	1.58 40	8.00 203
12" 300mm	MG-1012-HD12	12.57 319	2.36 60	1.58 40	12.00 305
14" 350mm	MG-1012-HD16	12.57 319	2.36 60	1.58 40	16.00 406
	MG-1216-HD16	14.12 359	2.56 65	2.36 60	16.00 406
16" 400mm	MG-1216-HD20	16.63 422	2.56 65	2.36 60	20.00 508
18-20" 450-500mm	MG-16-HD24	18.50 470	3.35 85	2.01 51	24.00 610
18-20" 450-500mm	GS-12A-HD20	18.50 470	7.00 178	2.63 67	20.00 508

Inch
Millimeter

Basic Valve

Cylinder & Valve

GS-2A & 4A 2-14" (50-350mm)

Valve Size	Dimensions					
	A	B	C	D	E	F
2-6" 50-150mm	11.62 295	1.47 37	4.91 125	6.35 161	4.76 121	1.53 39
8-12" 200-300mm	14.17 360	2.53 64	6.31 160	10.31 258	7.26 184	1.75 44
14" 350mm	19.21 488	3.66 93	7.19 183	10.25 260	11.35 288	2.06 52

Inch
Millimeter

GS-6A 12 & 14" (300-350mm)

Valve Size	Dimensions					
	A	B	C	D	E	F
12 & 14" 300-350mm	19.21 488	3.66 93	7.19 183	9.50 216	11.35 288	2.06 52

Inch
Millimeter

GS-12A 14-20" (350-500mm)

Valve Size	Cylinder	Dimensions					
		A	B	C	D	E	F
14" 350mm	GS-12A-PC8	30.88 784	6.88 175	7.75 197	8.50 216	17.50 436	2.63 67
	GS-12A-PC6	30.56 776	6.88 175	6.56 167	6.50 166	17.50 436	2.63 67
16" 400mm	GS-12A-PC8	30.88 784	6.88 175	7.75 197	8.50 216	17.50 436	2.63 67
	GS-12A-PC10	31.00 787	6.88 175	8.78 223	10.50 266	17.50 436	2.63 67
18" 450mm	GS-12A-PC8	30.88 784	6.88 175	7.75 197	8.50 216	17.50 436	2.63 67
	GS-12A-PC10	31.00 787	6.88 175	8.78 223	10.50 266	17.50 436	2.63 67
20" 500mm	GS-12A-PC8	30.88 784	6.88 175	7.75 197	8.50 216	17.50 436	2.63 67
	GS-12A-PC10	31.00 787	6.88 175	8.78 223	10.50 266	17.50 436	2.63 67

Inch
Millimeter

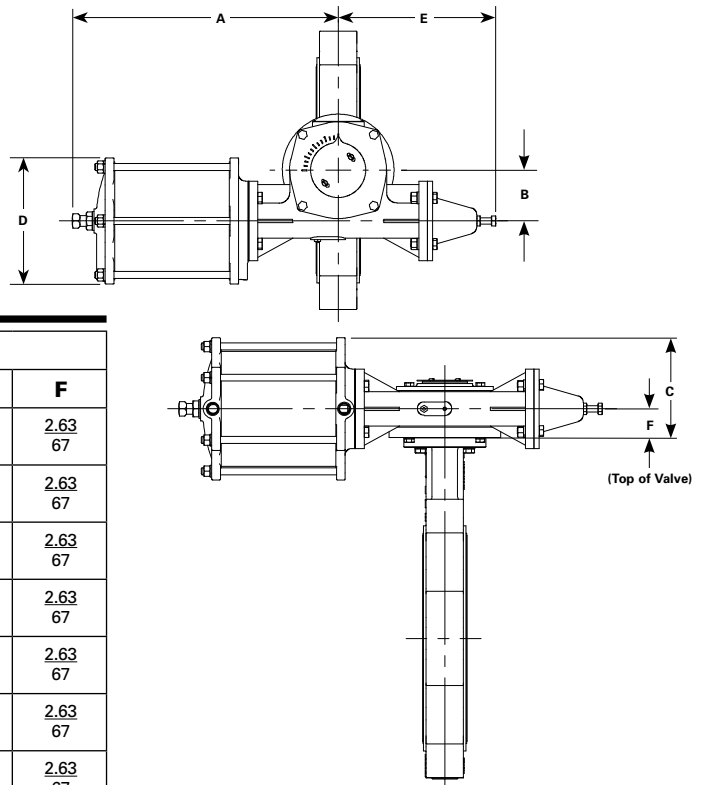
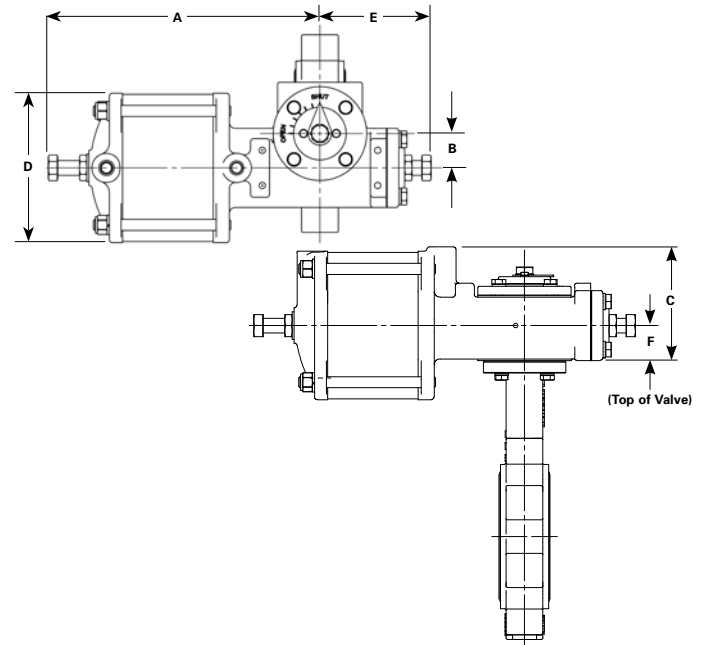

Sales and Service

For information about our worldwide locations, approvals, certifications and local representative:
Web Site: www.dezurik.com E-Mail: info@dezurik.com



250 Riverside Ave. N. Sartell, Minnesota 56377 • Phone: 320-259-2000 • Fax: 320-259-2227

DeZURIK reserves the right to incorporate our latest design and material changes without notice or obligation. Design features, materials of construction and dimensional data, as described in this bulletin, are provided for your information only and should not be relied upon unless confirmed in writing by DeZURIK. Certified drawings are available upon request.