

# C-20 CANAL GATE

- 10 foot Unseating Head
- Up to 35 foot Seating Head (see chart)
- Rugged Cast Bronze Lift Nut
- Machined Iron Seats, standard
- Rising Stems
- Adjustable Side Wedges

## USES:

The Waterman Model C-20 Canal Gate is made to fit the need for a moderate pressure cut-off where either moderate seating or low unseating pressures are encountered. Typical uses include installation in treatment plants, flood control projects, irrigation canals and diversion stands.

## FEATURES:

Flatback gates for headwall mounting or spigot back models for attaching to corrugated metal pipe are available.

The cover, frame ring, adjustable wedges, arch, and handwheel are made of cast iron. The lift nut is cast bronze and utilizes rugged acme type threads. The steel stem is secured to the cover by an easily removable pin to permit removing for maintenance. This feature also allows the user to stock standard frame length gates and provide field installation of rising stem extensions, where this is desirable.

Standard accessories, galvanizing, and bronze seats and stems are available.

Flatback flanges with 25# or 125# ANSI standard drilling available on special order.

A variety of sizes are available and custom requirements may be furnished.

- Stainless Steel Guide Rails and Stem, optional
- Bronze Seats, optional
- 25# and 125# ANSI drilling, optional



RECOMMENDED MAXIMUM SEATING and UNSEATING HEADS		
GATE SIZE	RECOMMENDED MAXIMUM SEATING HEAD	RECOMMENDED MAXIMUM UNSEATING HEAD
8" TO 12"	35 FEET	10 FEET
14" TO 18"	32 FEET	10 FEET
20" TO 24"	26 FEET	10 FEET
30" TO 42"	20 FEET	10 FEET

\* These recommendations are based upon design studies and modifications of this valve and upon years of installation evaluations.

# C-20 CANAL GATE DIMENSIONS

## NOTES

1. TYPE 2 lubricated ball bearing lift used on 42" gate.
2. Applies to spigotback gate only. Optional spigot, shown in phantom.
3. Drilling for mounting to 25 or 125 lb. pipe flange available for all gates. Due to gate design, bolt hole location (orientation) is straddle center drilling.
4. Add grout pad thickness to anchor bolt projection.

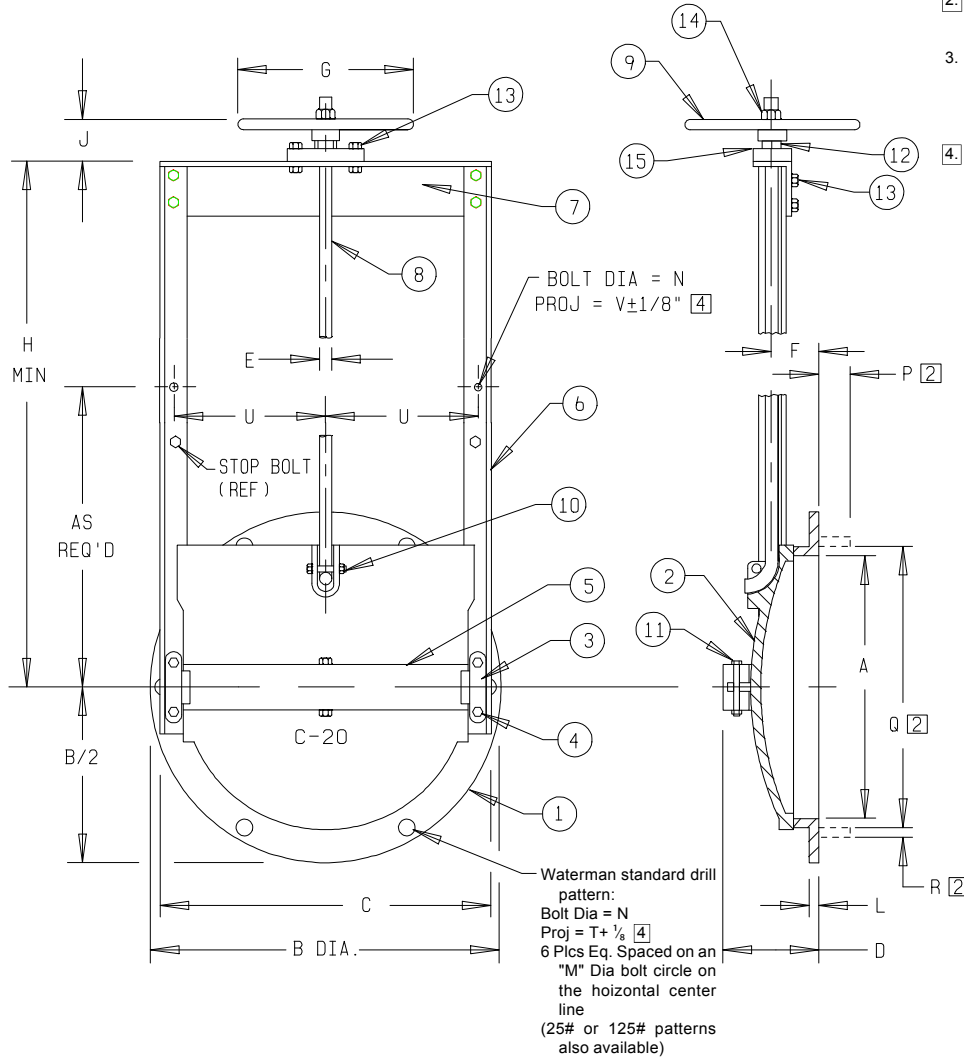

PARTS LIST	
No.	Name
1	FRAME
2	COVER
3	WEDGE (R & L)
4	WEDGE BOLTS
5	ARCH
6	GUIDE RAIL
7	HEAD RAIL
8	STEM
9	HANDWHEEL
10	STEM BOLT
11	ARCH BOLT & NUT
12	LIFT NUT
13	ATCH. HDW.
14	LIMIT NUT (optional)
15	LIFT COLLAR

GATE DIMENSIONS IN INCHES

A	B	C	D	E	F	G	H	J	L	M	N	P [2]	Q [2]	R [2]	T	U	V
8	13½	13⅞	5⅞	7⅞	3½	12	24	2⅞	5⅞	11⅞ <sub>16</sub>	½	2¼	9	5⅞ <sub>16</sub>	1½	5⅞ <sub>16</sub>	3¾
10	16	14½	6	7⅞	3½	12	24	2⅞	5⅞	14	½	2¼	11	3⅞	1½	6⅞ <sub>16</sub>	3¾
12	19	17½	6⅞ <sub>16</sub>	7⅞	3½	12	30	2⅞	5⅞	16¼	½	2¼	13	3⅞	1½	7½	3¾
14	21	19⅞	6⅞ <sub>16</sub>	7⅞	3⅞	12	32	2⅞	5⅞	18⅞ <sub>16</sub>	½	2¼	15	3⅞	1½	8½	3½
15	22½	20⅞	6¾	7⅞	3⅞	12	32	2⅞	5⅞	20	½	2¼	16	7⅞ <sub>16</sub>	1½	9	3½
16	23 ½	21⅞	7⅞	7⅞	3⅞	12	32	2⅞	5⅞	21	½	2¼	17	3⅞	1½	9⅞ <sub>16</sub>	3¾
18	25	24	8⅞	1⅞	4⅞	15	36	4	7⅞	23	5⅞	2¼	19	3⅞	2	10⅞ <sub>16</sub>	4½
20	27½	26	8¾	1⅞	4⅞	15	42	4	7⅞	25⅞	5⅞	2¼	21	3⅞	2	11¾	4½
21	28⅞	26¾	9	1⅞	4½	15	42	4	7⅞	26¾	5⅞	2¼	22	3⅞	2	12⅞ <sub>16</sub>	4¾
24	32	30¼	9⅞	1⅞	4¼	15	48	4	7⅞	30	5⅞	2¼	25	3⅞	2	13⅞ <sub>16</sub>	4½
30	39⅞	36½	10	1½	5⅞	18	60	4½	1	37½	¾	2¼	31	½	1¾	17	4¾
36	46	42½	12	1½	4½	18	70	4½	1	43½	¾	2¼	37	½	2	20	4½
42 [1]	53	49¾		1½	5⅞	24	84	6	1⅞	49½		2½	43	5⅞		23⅞ <sub>16</sub>	

# STEM EXTENSIONS

## RISING STEM EXTENSIONS (RSE)

For C-10, CL-10, CL-11 AND C-20 MODELS

Waterman Rising-Stem Extensions are factory installed to the height ("H") required. They provide a rising stem and handwheel, keeping threads and lifts above the water level and allowing the amount of gate opening to be readily determined. Cast iron brackets, fastened to the top and bottom of standard galvanized steel pipe, are secured to the frame headrail and mount to the standard handwheel and stem hardware.

The stem extends through the entire length of pipe. With the addition of oil seals, these rising stem extension can be used where weather conditions require that the stem operate in oil to prevent freezing.



RSE EXTENSION

Complete units are available from the factory when desired.

6" - 24" gates require 1 1/4" pipe  
 30" - 36" gates require 1 1/2" pipe  
 42" - 48" gates require 2" pipe

These extensions may also be adapted to C-20 gates.

Gate Size	A	B	M	H
6	3 7/8	2 7/8	24	VARIABLE AS REQUIRED
8	3 7/8	2 7/8	24	
10	3 7/8	2 7/8	24	
12	3 7/8	2 7/8	24	
14	3 7/8	2 7/8	27 1/2	
15	3 7/8	2 7/8	30	
16	3 7/8	2 7/8	32	
18	4 1/8	3 1/8	34	
20	4 1/8	3 1/8	38	
21	4 1/8	3 1/8	40	
24	4 1/8	3 1/8	44	
30	5	4	54	
36	5	4	62	
42	6	5	84	
48	7	6	90	
54	7	6	100	
60	7	6	102	
72	*	*	121	

All dimensions in inches and apply to C-10 Series gates.  
 \* Special fabricated design for geared type lift.

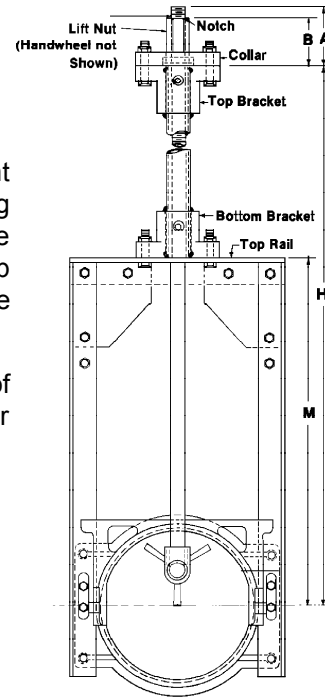

RISING STEM EXTENSION



NRS EXTENSION

## NON-RISING STEM EXTENSIONS

For C-10, CL-10, CL-11 AND C-20 MODELS

Waterman Non-Rising Stem Extensions are an accessory to Waterman stock gates. They are used to position the gate handwheel at convenient and non-changing operating elevations. This eliminates the problem of gate control hardware which might otherwise rise into traffic areas or walkways.

The use of Waterman Non-Rising Stem Extensions also eliminates the expense and inconvenience of ordering gates of special dimensions to meet different operating height conditions. The extensions are readily installed in the field. The upper and lower brackets are joined by a section of standard galvanized steel pipe (normally customer furnished) by means of threads, set screws, pins or welds. The length of pipe inserted determines the elevation of the handwheel. Waterman Stem Guide Models, such as Eye Bolt, NRS-K, SK-1, SK-2, K-1 and K-2 Series, are recommended to secure the handwheel location.

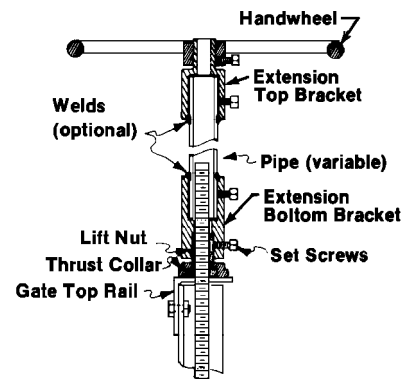

Normally Field Installed  
 NON-RISING STEM EXTENSION  
 Extends Handwheel Height  
 Without Disturbing Frame or Stem